

We Clean Air

SAFETY HALO®

Shield yourself, your employees and your products from dangerous air-borne pathogens!

Safety Halos® help protect workers by surrounding them with a cone of air cleaner than that of an N95 mask.

Developed Based on Patented Military Grade Technology Tested and Proven by NIOSH to Protect Miners in Coal Mines

NIOSH is the National Institute for Occupational Safety & Health, and is part of the US Center for Disease Control and Prevention (CDC)

Do your employees or co-workers worry about health risks on the job?

Improve protection for your workforce with a Safety Halo®!

WHAT IS A SAFETY HALO®?

- A specially-developed air-cleaning unit that mounts on a movable stand, legs, or hangs from the ceiling.
- The Safety Halo® provides:
 - A cone of air flowing gently downward and outward to help keep away germs exhaled by people breathing.
And
 - A cone of HEPA-filtered air moving downward and outward around your body to help move airborne contaminants away from your face.
- Safety Halos® produce cleaner and safer air than an N95 face mask.
- Safety Halos® will help protect people, food, equipment and other surfaces from dust, germs, pollen and other contaminants long after the COVID-19 pandemic ends.
- Safety Halos® utilize patented air cleaning blower technology that currently protects people and equipment of Nucor Steel, Mitsubishi, and the US Navy to minimize maintenance and other operating costs.

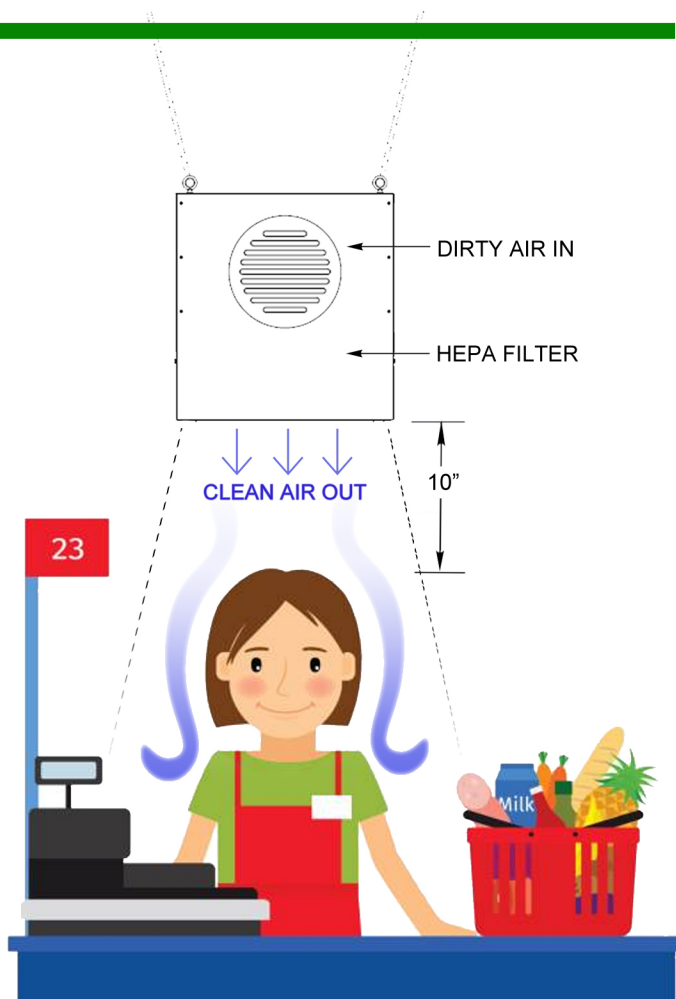

SAFETY HALO® OPTIONS

- Can also cool or heat those underneath.
- Join units together to protect larger areas such as:
 - Fast Food Counters
 - Store Displays
 - Production Lines
 - Elevators

180 South Street Suite H, Highland, NY 12528
(845) 244-3091
www.WeCleanAir.com

Check out our website:



HOW DOES IT WORK?

The Safety Halo® works in a revolutionary way by blowing clean air around your busy employees. It produces a cone of HEPA-filtered air that flows down with a positive pressure that resists the movement of particles into and through it. The protective air also carries many of those particles that do penetrate the cone downward and outward, away from the worker's face and protected products and surfaces.

Features of Safety Halos®

Super cleans air with a HEPA filter

Easy to install, use and maintain

Use indoors and outdoors

Hang from ceilings, legs, or movable bases

Besides germs, Safety Halos® remove smoke, pollen, industrial, agricultural and desert dusts, and many other unwanted or hazardous contaminants

USERS / APPLICATIONS



Cashier in Stores
Nurses Station
Medical Receptionist
Chef / Cook
Toll Booth Clerk
Drive-Through Window
Librarian
Assembly Line Worker

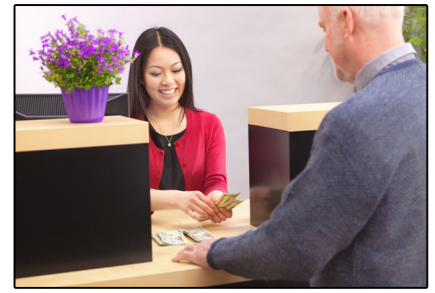

Infectious-disease doctors have recently found that the novel coronavirus spreads through droplets expelled from infected people coughing, sneezing or talking. Safety Halos® remove and block those air-borne droplets.

180 South Street Suite H, Highland, NY 12528
(845) 244-3091
www.WeCleanAir.com

Visit our website:



Safety Halos® ARE EASY TO INSTALL!

Hang them up!

Plug them in!

That's it!

No drilling, cutting or welding required!

Cables and clips included,
hangs from ceiling
or moveable stand.



Standard units run on 115-125
volts, with other
configurations available.

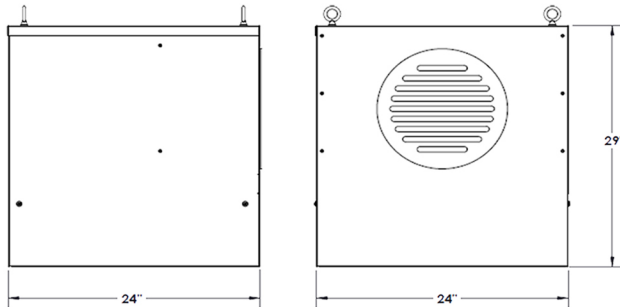

CONTACT **WE CLEAN AIR** TODAY AND WE'LL HELP YOU CHOOSE
THE BEST SYSTEM TO PROTECT YOU & YOUR TEAM!

Marketing@WeCleanAir.com

845-244-3091

www.WeCleanAir.com

MADE IN THE U.S.A.

We Clean Air is an Air Cleaning Blowers, LLC Company

We Clean Air
180 South Street Suite H
Highland, NY 12528

(845) 244-3091
Marketing@WeCleanAir.com
www.WeCleanAir.com

Distributed By: